

WIRELESS MOBILE CHARGER USING **MAGNETIC INDUCTION**

PROJECT REPORT

Submitted by

N SORNAMUHI

Register No : AB19PHY019

Under the guidance of

Dr. Sunsu Kurian, Assistant Professor

Department of Physics, St.Teresa's College(Autonomous),

Ernakulam

Kochi, 682011

Submitted to

Mahatma Gandhi University, Kottayam

In partial fulfillment of the requirement for the award of

BACHELOR'S DEGREE OF SCIENCE IN PHYSICS



ST. TERESA'S COLLEGE (AUTONOMOUS)



ST. TERESA'S COLLEGE (AUTONOMOUS)
ERNAKULAM



**B.Sc. PHYSICS PROJECT
REPORT**

Name : N SORNAMUHI
Register Number : AB19PHY019
Year of work : 2021-2022

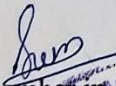
This is to certify that this project entitled 'WIRELESS MOBILE CHARGER USING MAGNETIC INDUCTION' is a bonafide work done by N SORNAMUHI.

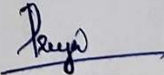

Staff member in charge
Dr. Sunsu Kurian



Head of the Department
Dr. Priya Parvathi Ameen Jose

submitted for the University examination held at St. Teresa's College, Ernakulam

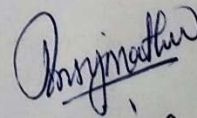
DATE: 9/05/2022

EXAMINERS:



Susan

**ST.TERESA'S COLLEGE (AUTONOMOUS)
ERNAKULAM**



CERTIFICATE

This is to certify that the project report entitled “**WIRELESS MOBILE CHARGER USING MAGNETIC INDUCTION**” is a bonafide work by N SORNAMUHI, St.Teresa's College Ernakulam, under my supervision at the Department of Physics, St.Teresa's College, Ernakulam for the partial fulfillment of the award of Degree Of Bachelor of Science in Physics during the academic year 2021-'22 .The work presented in this dissertation has not been submitted for any other degree in this or any other university.

Dr. Sunsu Kurian
Assistant professor
Supervising Guide

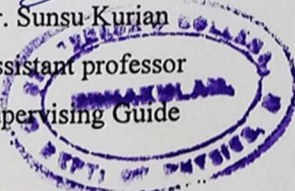

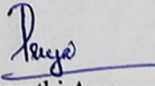
Dr. Priya Parvathi Ameena Jose
Assistant professor
Head of Department

PLACE: ERNAKULAM

DATE: 9/05/2022

ACKNOWLEDGMENT

DECLARATION

I, **N SORNAMUHI (Register Number: AB19PHY019)**, final year B.Sc. Physics student, Department of Physics, St. Teresa's College, Ernakulam do hereby declare that the project work entitled "**WIRELESS MOBILE CHARGER USING MAGNETIC INDUCTION**" has been originally carried out under the guidance and supervision of Dr. Sunsu Kurian, Assistant Professor, Department of Physics, St. Teresa's College (Autonomous), Ernakulam in partial fulfillment for the award of the Degree of Bachelor of Physics. I further declare that this project is not partially or wholly submitted for any other purpose and the data included in the project is collected from various sources and are true to the best of my knowledge.



N.Sornamuhi

PLACE: ERNAKULAM

DATE : 9/05/2022

ACKNOWLEDGMENT

I would like to express my gratitude and appreciation to all those who gave us the possibility to complete this report. I feel obliged to acknowledge the support and guidance that came from various quarters during the course of competition of this project. I would like to express our sincere gratitude to Dr. Sunsu Kurian, the project in charge, for guiding us throughout the entire duration of the project work, whose help, stimulating suggestions and encouragement helped us in all time of fabrication process and in writing this report.

I would also like to acknowledge with much appreciation the crucial role of the staff in the Physics Laboratory, who gave us permission to use the lab equipments and helped us in times of need. I would also like to extend our sincere thanks to all the faculty members of the Physics Department for their valuable suggestions and corrections. My profound thanks go to all our classmates for lending their support and my teammates for working tirelessly and continuously with me on this project.

CONTENTS

ABSTRACT	
CHAPTER 1: INTRODUCTION	8
CHAPTER 2: PROBLEM STATEMENT	10
CHAPTER 3: PRINCIPLE OF WORKING	11-14
3.1 Electromagnetic Induction	
3.2 Inductive Coupling	
CHAPTER 4: OVERVIEW OF COMPONENTS	15-27
4.1 Hardware specifications	
CHAPTER 5: METHODOLOGY	28-36
5.1 Circuit Diagram	
5.2 Working of the system	
5.3 Design Calculation	
5.4 Observations	
CHAPTER 6: CONCLUSION	37
CHAPTER 7: MERITS, CHALLENGES AND FUTURE SCOPE	38-39
REFERENCES	

ABSTRACT

The main objective of this project is to demonstrate the concept of wireless mobile charging system using the principle of inductive coupling. The system allows users to wirelessly charge their mobile phones without plugging in the mobile adapter. It is demonstrated using a charging pad where users just need to place their adapter circuit to charge their mobile phone. The system is based on a coupling magnetic field, thus designed and constructed as two parts: the transmitter part and receiver part. An oscillation circuit converts DC energy to AC energy to transmit magnetic field by passing frequency and then induce the receiver coil. The Ampere's law, Biot Savart's law and Faraday law are used to calculate the inductive coupling between the transmitter coil and the receiver coil. We have constructed a wireless mobile charger using magnetic induction and the efficiency of the system is calculated by varying the distance between the coils.

CHAPTER 1

INTRODUCTION

In this modern era, Wireless and Telecommunication have become an integral part of each other to provide wireless communication to the common man that helps people located in any part of the world communicate easily. This technology transmits information over the air using electromagnetic waves like infrared, radiofrequency, satellite, etc. For example, GPS, Wi-Fi, satellite television, wireless computer parts, wireless phones that include 3G and 4G networks, and Bluetooth. Wireless charging technology enables wireless power transfer from a power source such as a charger to a load such as a mobile device conveniently across an air gap by eliminating the bunch of wires. The development of this technology started in the late 19th and early 20th centuries, when a number of important innovations in electromagnetic research were made. These advancements established the basic principles that served as the foundation for modern electrical power transport.

Wireless technology makes our life more convenient and easier. Imagine sitting on a sofa and reading the newspaper, and automatically charging your mobile phone by placing it on a table without the need of getting a wired charger and plugging it to a supply. You can simply grab your mobile phone at any time and charge it wherever you are- home, the office, the library, the local coffee shop. It has numerous applications like for pacemakers, MP3 players, toothbrushes, iPod, digital cameras, laptops, etc.

There are a number of methods for transmitting power wirelessly. The most popular and effective of which are inductive coupling, resonant inductive coupling, capacitive coupling, radio frequency and microwave power transmission, and laser power beaming. One of the oldest techniques of transferring energy wirelessly is inductive coupling. An inductor is a wire formed into a coil where an induced current produces a magnetic field which is based on the principle of electromagnetic induction. Electromagnetic or magnetic induction is the production of an electromotive force across an electrical conductor in a changing magnetic field. Michael Faraday is generally credited with the discovery of induction in 1831, and James Clerk Maxwell mathematically described it as Faraday's law of induction.

The project demonstrates the concept of wireless mobile charging system. The efficiency of the system is calculated by varying the distance between the coils. Graphs between the efficiency and distance are plotted for its performance analysis. The system allows users to wirelessly charge their mobile phones without plugging in the mobile adapter. The system is demonstrated using a charging pad where users just need to place their adapter circuit to charge the mobile phone.

CHAPTER 2

PROBLEM STATEMENT

Wireless Charging is one technology that looks very promising in today's tech world. Most, if not all high-end Smartphones these days come with the Wireless Charging feature and for those smartphones that don't come with the feature, you can always buy a Wireless Charging Case. This will enable you to charge your smartphone wirelessly simply by placing the smartphone on the charging pad.

The biggest disadvantage of wired technology is that it lacks the mobility that wireless technology provides. You are physically limited to the reach of the cable, whereas wireless technology allows users to move great distances freely and without hassle. Moving equipment that is even within the range of the cable may be difficult if you choose to mount the cables rather than have them dangling. Another physical constraint of wired technology is that wires can be easily damaged, which is not as large of a concern with wireless technology. Exposed cables are susceptible to everyday abuse from things such as cleaning. Wires that are exposed and not properly laid may also pose a tripping risk, not only damaging the cable but also potentially sending someone to the emergency room. Damaged wires may have to be completely replaced.

Using a wireless charger gives your USB Port more free time and subsequently increases the lifespan. There is no doubt that using wired chargers leads to the USB Port getting more action which can damage the port. Using a wireless charger leaves the USB Port for only when you need to connect to another device like computers, hard drives, TV etc which if we are to be honest happens less frequently than charging. Wireless networks are cheaper to install and maintain. The data is transmitted faster and at a high speed.

The study is therefore aimed at eliminating the problems of wired technology and demonstrating the easiness of wireless communication systems promoting greater convenience and ubiquity for charging everyday devices. By designing and constructing a method by circuit to transmit electrical power wirelessly from source to device, we will eliminate the use of cables in the charging process, thus making it simpler and easier to charge a low power device. It would also ensure the safety of the device since it would eliminate the risk of short circuit.

CHAPTER 3

PRINCIPLE OF WORKING

3.1. ELECTROMAGNETIC INDUCTION

Ørsted was able to demonstrate that electric currents can produce magnetic fields by setting up a compass through a wire carrying an electric current. The English physicist Michael Faraday, a brilliant experimentalist, was the first to demonstrate the converse effect that magnetic fields can be used to induce electric currents. Faraday wrapped a thick iron ring with two coils of insulated wire, one on each side of the ring. One coil was connected to a battery, and the other to a galvanometer. When the battery circuit was closed, Faraday saw a momentary deflection on the galvanometer. A similar momentary deflection but in the opposite direction was seen when the battery circuit was opened.

This observation led to the discovery that a change in a magnetic field produces an electromotive force and current in a nearby circuit. This phenomenon, called electromagnetic induction, was later mathematically modeled by James Clerk Maxwell and came to be known as Faraday's Law. The foundation laid by Faraday helped Maxwell further investigate electromagnetic field theory, and the latter's contribution then significantly influenced 20th century physics. Faraday's law of induction describes how an electric current produces a magnetic field and, conversely, how a changing magnetic field generates an electric current in a conductor. The American physicist Joseph Henry independently made the same discovery at about the same time, according to the University of Texas at Austin.

Faraday explained electromagnetic induction using a concept he called lines of force. Coils of wire in the base station (the charging plate) create a magnetic field as the current passes through. This field can induce an electrical current in an adjacent coil of wire without actually touching it. Inductive charging uses an electromagnetic field to transfer energy between two objects. This is usually done with a charging station. Energy is sent through an inductive coupling to an electrical device, which can then use that energy to charge batteries or run the device.

Faraday's Law states that the amount of voltage induced in a coil is directly proportional to the rate of change of the magnetic flux with respect to the coil, $d\phi/dt$ and to the number of turns of wire in the coil (N). The formula that represents Faraday's Law is the following:

$$V = N \frac{d\phi}{dt} \dots\dots\dots(1)$$

where V= the induced voltage

N = number of turns of wire in the coil

$\frac{d\phi}{dt}$ = the rate of change of the magnetic flux

In an AC circuit, the induced voltage is directly dependent on frequency. As frequency increases so does the rate of change of the current. The formula of inductance is as follows:

$$L = \frac{N\mu A}{l} \dots\dots\dots(2)$$

$$\mu = \mu_r \mu_0$$

where L = inductance of coil in Henrys

N = Number of turns in wire of coil

μ = Permeability of core material

μ_r = Relative permeability (1 for air)

μ_0 = Permeability of free space ($4\pi \times 10^{-7} \mu/m$)

A = Area of coil in square meters

l = Average length of coil in meters

3.2. Inductive Coupling

Two conductors are said to be inductively coupled or magnetically coupled when they are configured in a way such that change in current through one wire induces a voltage across the ends of the other wire through electromagnetic induction. A changing current through the first wire creates a changing magnetic field around it by Ampere's circuital law. The changing magnetic field induces an electromotive force (EMF or voltage) in the second wire by Faraday's law of induction. The amount of inductive coupling between two conductors is measured by their mutual inductance. The coupling between two wires can be increased by winding them into coils and placing them close together on a common axis, so the magnetic field of one coil passes through the other coil. Coupling can also be increased by a magnetic core of a ferromagnetic material like iron or ferrite in the coils, which increases the magnetic flux. The two coils may be physically contained in a single unit, as in the primary and secondary windings of a transformer, or may be separated.

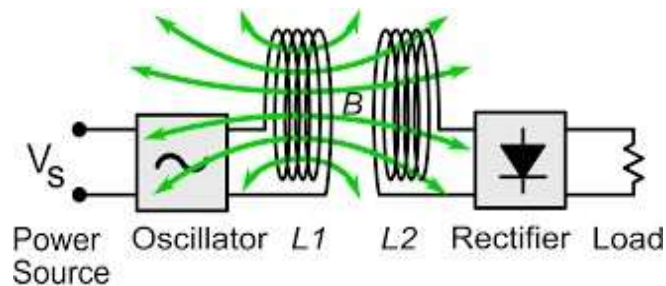

Fig 1. Simplified Circuit Illustrating Inductive Coupling

Consider a coil through which a current is passed. This creates a changing magnetic field around it. When a second coil is introduced to a changing magnetic field of the primary coil, it will cause an induced voltage in the second coil, thereby magnetically coupling the coils. The voltage induced in the second coil is a function of mutual inductance, calculated by the following formula:

$$L_M = k\sqrt{L_1 L_2}$$

Where L_M = Mutual inductance

$$k = \frac{\phi_1}{\phi_2}, \text{ coefficient coupling between the two coils}$$

$$L_1 = \text{Inductance of coil 1}$$

$$L_2 = \text{Inductance of coil 2}$$

The formulas above describe the principles of induction and how voltage is induced in a second coil.

In the circuit, the transmitter has an AC source which is connected to a resistor (R_p) and an inductor (L_1), where the resistor represents power loss due to heat. As inductor 1 (L_1) receives the fluctuating current from the AC source it creates a magnetic field and induces voltage in L_2 . The receiver circuit which has L_2 , R_s , and R_L is powered by the changing magnetic field of the transmitter. Again, R_s represents the power loss of the inductor and R_L is the load.

Power transfer efficiency of inductive coupling can be increased by increasing the number of turns in the coil, the strength of the current, the area of cross-section of the coil and the strength of the radial magnetic field. Magnetic fields decay quickly, making inductive coupling effective at a very short range. There have been some attempts to reduce transfer loss in inductive coupling. Methods such as implementing ultra-thin coils, higher frequencies, and enhancing drive electronics are possible solutions. When implementing higher frequency induction to deliver high power the efficiency reaches 86%, the other two methods are still being investigated for any improvements.

CHAPTER – 4

OVERVIEW OF COMPONENTS

The hardware components required to design the proposed system of wireless mobile charger are :-

- 1) Copper wire (25 gauge)
- 2) IRFZ44N MOSFET
- 3) 9 volt Battery
- 4) IC4007 diode
- 5) 1000 μ F capacitor
- 6) LM7805
- 7) 1 K Ω resistor
- 8) LED
- 9) Switch
- 10) Breadboard
- 11) Charging pin
- 12) Battery cap

4.1. HARDWARE SPECIFICATIONS:-

1. Copper wire

A copper wire is a single electrical conductor made of copper. Copper has the lowest resistance to the flow of electricity of all non-precious metals. It is highly conductive as in a copper atom, the outermost 4s energy zone, or conduction band, is only half filled, so many electrons are able to carry electric current. When an electric field is applied to a copper wire, the conduction of electrons accelerates towards the electropositive end, thereby creating a current. These electrons encounter resistance to their passage by colliding with impurity atoms, vacancies, lattice ions, and imperfections. It has high tensile strength thus resists stretching, neck-down, creep, nicks and breaks, and thereby also prevents failures and service interruptions. Copper has a higher ductility than alternate metal conductors with the exception of gold and silver hence it is easy to draw down

to diameters with very close tolerances. Copper has excellent creep characteristics that minimizes loosening at connections. It resists corrosion from moisture, humidity, industrial pollution, and other atmospheric influences. However, any corrosion oxides, chlorides, and sulfides that do form on copper are somewhat conductive. It has a low coefficient of thermal expansion thus can be readily soldered to make durable connections when necessary. The strength, hardness, and flexibility of copper make it very easy to work with.



Fig 2. Copper wire of 25 gauge

The copper wire used in the proposed system is of 25 gauge.

Copper wires are the most widely used conductor in many kinds of electrical wiring. Copper wire and cables are used in power generation, power transmission, power distribution, telecommunications, electronics circuitry, and countless types of electrical equipment.

2. Battery

An electric battery is a source of electric power consisting of one or more electrochemical cells with external connections for powering electrical devices. When a battery is supplying power, its positive terminal is the cathode and its negative terminal is the anode. The terminal marked negative is the source of electrons that will flow through an external electric circuit to the positive terminal. When a battery is connected to an external electric load, a redox reaction converts high-energy reactants to lower-energy products, and the free-energy difference is delivered to the external circuit as electrical energy.

Batteries convert chemical energy directly to electrical energy. It consists of some number of voltaic cells. Each cell consists of two half-cells connected in series by a conductive electrolyte containing metal cations. One half-cell includes electrolyte and the negative electrode, the electrode to which anions (negatively charged ions) migrate; the other half-cell includes electrolyte and the positive

electrode, to which cations (positively charged ions) migrate. Cations are reduced (electrons are added) at the cathode, while metal atoms are oxidized (electrons are removed) at the anode. Some cells use different electrolytes for each half-cell; then a separator is used to prevent mixing of the electrolytes while allowing ions to flow between half-cells to complete the electrical circuit.

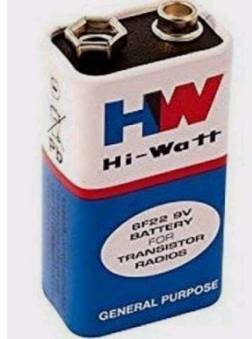

Fig 3. Battery (9v)

The power source used in the proposed system is a 9v battery.

3. IRFZ44N MOSFET

MOSFET is an abbreviation for metal-oxide semiconductor field-effect transistors. It has a source, gate, and drain. The gate of a MOSFET is insulated from the channel. Because of this MOSFET is known as an IGFET which stands for insulated-gate field effect transistor. Unlike transistors, MOSFETs are voltage controlled devices i.e. they can be turned on or turned off by supplying the required Gate threshold voltage (V_{GS}).

There are two basic types of MOSFETs :-

- i) Depletion type MOSFET (D-type MOSFET)
- ii) Enhancement type MOSFET (E-type MOSFET)

The primary difference between the two types of MOSFETs is the difference between the constructions.

The IRFZ44N is a N-channel enhancement type MOSFET with a high drain current of 49A and low R_{ds} value of 17.5 m Ω which help in increasing the efficiency of switching circuits. It also has a low threshold voltage of 4V at which the MOSFET will start conducting. Hence it is commonly used with microcontrollers to drive with 5V. The pulsed drain current (I_{D-peak}) is 160A, minimum gate

threshold voltage (V_{GS-th}) is 2V, maximum gate threshold voltage (V_{GS-th}) is 4V, gate-source voltage is (V_{GS}) is $\pm 20V$ (max), maximum drain-source voltage (V_{DS}) is 55V.



Fig 4. IRFZ44N MOSFET

IRFZ44N Pinout Configuration

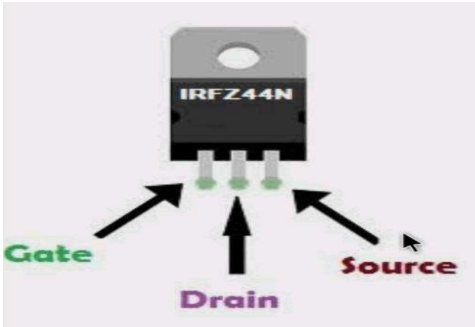

Fig 5. Pinout configuration of IRFZ44N MOSFET

Pin name and corresponding functions

Pin Number	Pin Name	Description
1	Gate	Controls the biasing of the MOSFET
2	Drain	Current flows in through Drain
3	Source	Current flows out through Source

Table 1

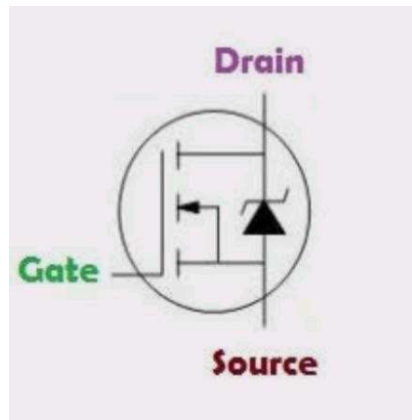

Fig 6. Symbol of IRFZ44N MOSFET

IRFZ44N is an N-channel MOSFET, so the Drain and Source pins will be left open when there is no voltage applied to the gate pin. When a gate voltage is applied these pins get closed. If it is required to be switched with Arduino, then a simple drive circuit using a transistor will work to provide the required gate voltage to trigger the MOSFET to open fully. For other switching and amplifying applications, a dedicated MOSFET Driver IC is required.

Its applications are in switching high power devices, to control the speed of motors, in LED dimmers or flashers, in high speed switching applications, converters or inverter circuits. By using MOSFET in wireless power transmission it creates the output with high frequency improves the efficiency of power transfer between the coils. Here, it also functions as DC to AC inverter.

4. IN4007 diode

A diode is a device which allows current flow through only one direction. That is the current should always flow from the anode to cathode. The cathode terminal can be identified by using a grey bar. The maximum current carrying capacity is 1A it withstand peaks up to 30A. Hence we can use this in circuits that are designed for less than 1A. The reverse current is 5 μ A which is negligible. The power dissipation of this diode is 3W. Its peak repetitive reverse voltage is 1000V.



Fig 7. 1N4007 Diode

Pin Configuration



Fig 8. 1N4007 Diode pin configuration

Pin and corresponding functions

	Pin Name	Description
1	Anode	Current always Enters through Anode
2	Cathode	Current always Exits through Cathode

Table 2

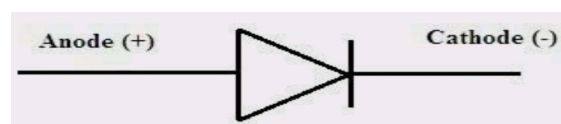

Fig 9. Symbol of diode

The IN4007 diode can be used to prevent reverse polarity problems. They are used in half wave and full wave rectifiers .And also used as protection devices and current flow regulators.

5. Capacitor

Capacitors an electrical or electronic component that stores electric charges. Basically, a capacitor consists of 2 parallel plates made up of conducting materials, and a dielectric material (air, mica, paper, plastic, etc.) placed between them.

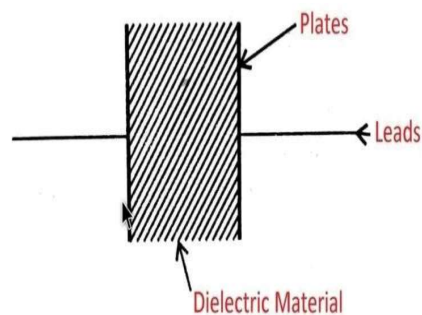

Fig 10. Capacitor

Different types of capacitors are :- Fixed Capacitors, Mica Capacitors, Ceramic Capacitors, Paper Capacitors, Plastic Capacitors, Electrolytic Capacitors, Film capacitor, Adjustable Capacitors, Variable Capacitors.

Electrolytic Capacitors



Fig 11. Electrolytic capacitor (1000 µF)

Electrolytic capacitors are polarized capacitors so these are used where energy with required polarity is necessary. Here oxide film obtained by a chemical reaction acts as a dielectric material.

Electrolytic capacitors are further classified into: -

- i) Wet Type Electrolytic Capacitor
- ii) Dry Type Electrolytic Capacitor

Wet Type Electrolytic Capacitor

It consists of an aluminum rod placed in a base electrolyte placed in an aluminum container. Now D.C. current is passed through the container, with the help of the D.C. source connected between rod and container. A thin film of oxide is deposited on the rod, which is connected to a positive terminal of the source. Thus the rod acts as a positive terminal of the capacitor. The source is switched off when the rod is covered by oxide film completely. Thus rod acts as (+)ve terminal, container as (-)ve terminal with oxide film as a dielectric material.

Dry Type Electrolytic Capacitor

It contains two aluminum sheets separated by a layer of gauze separator saturated with a liquid chemical of boric acid. Copper lead wires are soldered to the aluminum foils for external connection. D.C. voltage is applied to the copper leads, which deposited aluminum oxide film on the foil that is connected to a positive terminal of the supply. so that foil acts as (+)ve terminal and other foil acts as (-)ve terminal. Now the foils are rolled into a cylindrical shape and enclosed in an aluminum or plastic tube.

An electrolytic capacitor of 1000 μ F.

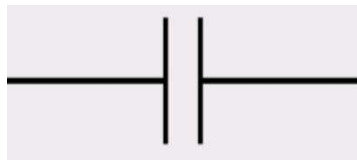

Fig 12. Symbol of capacitor

Capacitors are used as filters in rectifier circuits, as bypass capacitors in amplifier circuits. They are also used in T.V. and radio receivers for tuning purposes.

6. LM7805

The 7805 Voltage Regulator IC is a commonly used voltage regulator that finds its application in most of the electronics projects. It provides a constant +5V output voltage for a variable input voltage supply. 7805 IC is an iconic regulator IC that finds its application in most of the projects. The name 7805 signifies two meanings, “78” means that it is a positive voltage regulator and “05” means that it provides 5V as output. Hence 7805 will provide a +5V output voltage.

The output current of this IC can go up to 1.5A. But, it suffers from heavy heat loss. Hence, usually a heat sink is recommended for projects that consume more current.

Its minimum input voltage is 7V and maximum input voltage is 25V. The operating current is 5 mA. Internal thermal overload and short circuit current limiting protection is available in this. Maximum junction temperature is 125 degree celsius.

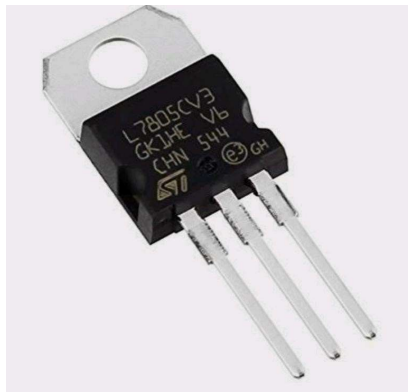

Fig 13. LM7805

LM7805 Pinout Configuration

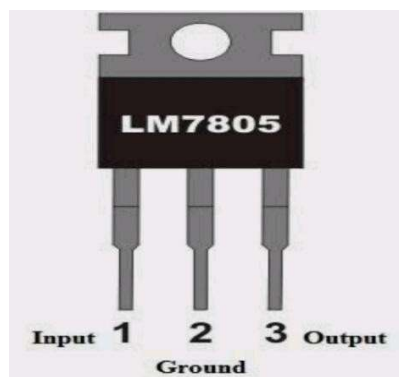

Fig 14. LM7805 pin configuration

Pin and corresponding functions

Pin Number	Pin Name	Description
1	Input (V+)	Unregulated Input Voltage
2	Ground (Gnd)	Connected to Ground
3	Output (Vo)	Outputs Regulated +5V

Table 2

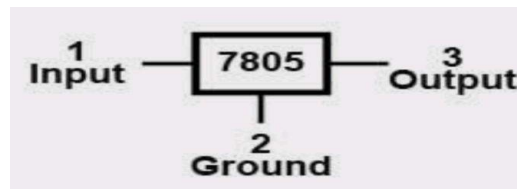

Fig 15. Symbol of LM7805

Voltage regulators are very common in electronic circuits. It is used as a constant 5V output regulator to power microcontrollers and sensors. They are also used as current limiters for certain applications. Also used as an output polarity reversal protection circuit.

7. Resistors

A resistor is a passive electronic component and senses to prevent or limit the flow of electrons. It is a two terminal device that works on the principle of ohm's law which prevents overflow of voltage. Resistance can be derived from ohm's law i.e. $V=IR$, which indicates that voltage is directly proportional to the current flowing through the conductor. Each resistor comes with two wires called leads. Between these two leads there lies a ceramic part which actually resists the flow of current. Resistor consists of 3 colored strips that indicate the value of resistance.

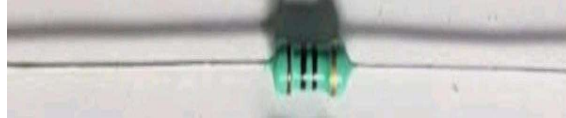

Fig 16. Resistor



Fig 17. Symbol of Resistor

The resistor used in the proposed system is 1 K Ω resistor

8. LED (Light emitting diode)

LED is a PN junction diode which emits light when forward biased, is known as a light emitting diode. The LED has two legs, one is shorter and the other is longer. The longer leg is known as anode and the shorter leg is cathode. The LED is available in different colours like white, red, blue etc., which depends upon the semiconducting material used for LED fabrication and its band gap energy.



Fig 18. LED

When the LED is forward biased, the electrons and holes move towards the junction and recombination takes place. This effect is called electro-illumination. After the recombination, the electrons, lying in the conduction band of the N region, fall into the holes lying in the valence band of the P region. The difference of energy between the conduction band and valence band is radiated in the form of light energy. The amount of light output is directly proportional to the forward current. Thus, the higher the forward current the higher is the light output.

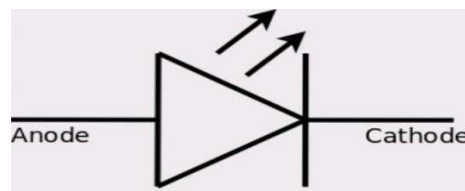

Fig 19. Symbol of LED

Usually, Indium gallium nitride and Aluminum gallium indium phosphide are used for LED fabrication.

9. Switch

A switch is an electrical component that can disconnect or connect the conducting path in an electrical circuit, interrupting the electric current or diverting it from one conductor to another. The most common type of switch is an electromechanical device consisting of one or more sets of movable electrical contacts connected to external circuits. When a pair of contacts is touching current can pass between them, while when the contacts are separated no current can flow.

The switch that we use in this circuit is the Rocket switch. They are used for operations that can be pressed on either end like a seesaw to connect or disconnect an electrical circuit. They are often used as ON/OFF switches on the main power supplies for electronic devices. The name “rocker switch” comes from the rocking motion that the switch makes when the button is pressed. It is also sometimes called a seesaw switch.



Fig 20. Rocket switch

It has a small size and high switching capacity. The operation button itself clearly indicates the ON/OFF status, allowing for a visual confirmation to prevent incorrect operation.



Fig 21. Symbol of Switch

An ideal switch would have no voltage drop when closed, and would have no limits on voltage or current rating. It would have zero rise time and fall time during state changes, and would change state without bouncing between on and off positions.

10. Breadboard

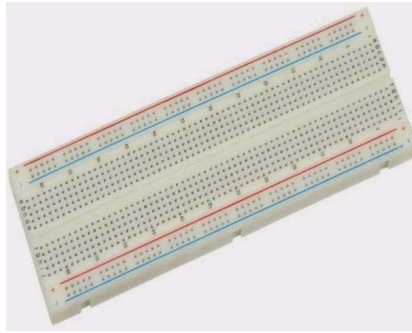

Fig 22. Breadboard

A Breadboard, also known as a protoboard, is a construction base for prototyping of electronics. The word referred to a literal breadboard, a polished piece of wood used for slicing bread. Later, solderless breadboards became available as it does not require soldering, and is used for creating temporary prototypes and experimenting with circuit design which means it is reusable and because of this reason it is popular among students for many projects. The bread board consists of clips which are called tie or contact points, the clips will be maintaining a gap of 2.54mm between each one of them. They are connected from pin to other pins using metal strips.

CHAPTER - 5

METHODOLOGY

Wireless charging technology enables wireless power transfer from a power source such as charger to a load such as a mobile device conveniently across an air gap by eliminating the bunch of wire. Wireless power transmission involves the exchange of power without the need for physical connections.

5.1. CIRCUIT DIAGRAM:

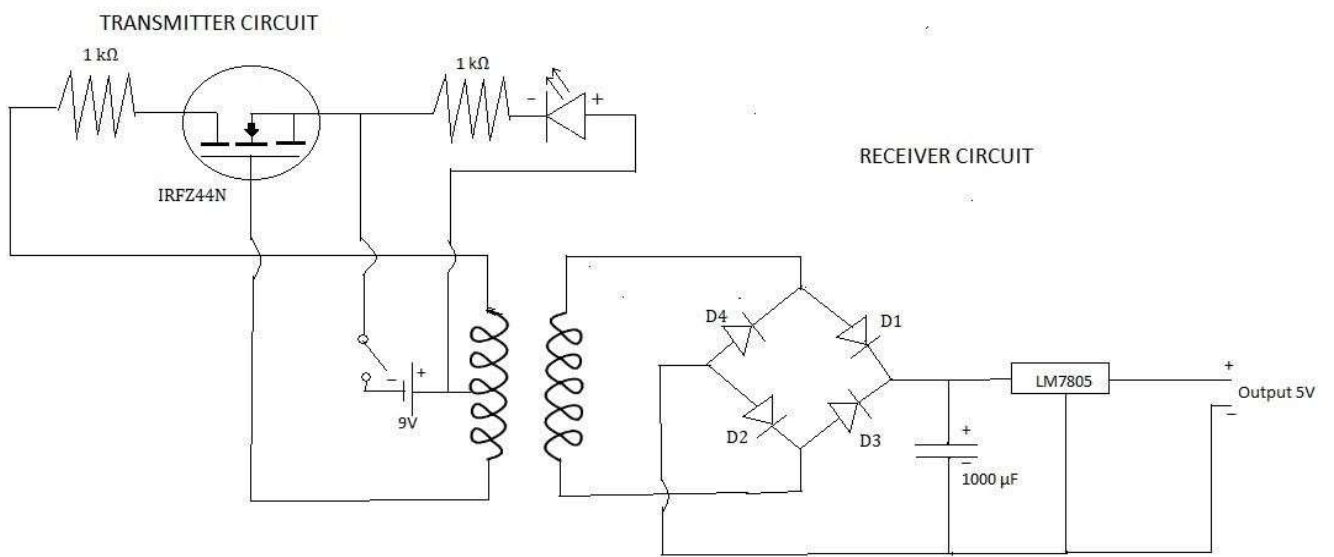

Fig 23. Circuit diagram

5.2. WORKING OF THE SYSTEM :

The circuit for wireless power transfer consists of a 9V Battery, rectifier, LC oscillator circuit, transmitter, receiver and current amplifier, voltage regulator.

Current amplifier:

Here we use MOSFET Z44 to invert the DC current to AC. It also works as a current amplifier, so that it increases the efficiency of the coil.

Transmitter coil:

Power supply is given to the transmitter. Copper coil is wound into several turns. When power supply is given to the coil, a magnetic field is produced. Hence the power gets transferred.

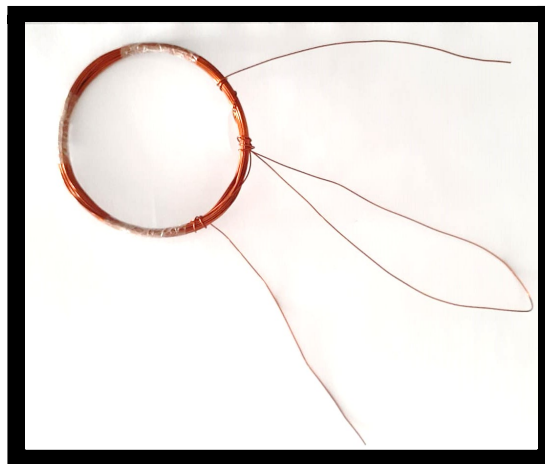

Fig 24. Transmitter coil

Receiver coil:

The receiver coil is the secondary coil and has the same design as the primary coil. Running the secondary at the same resonant frequency as the primary ensures that the secondary has low impedance at the transmitter's frequency and that the energy is optimally absorbed. To remove energy from the secondary coil, different methods can be used, the AC can be directly rectified and a regulator circuit can be used to generate DC voltage.

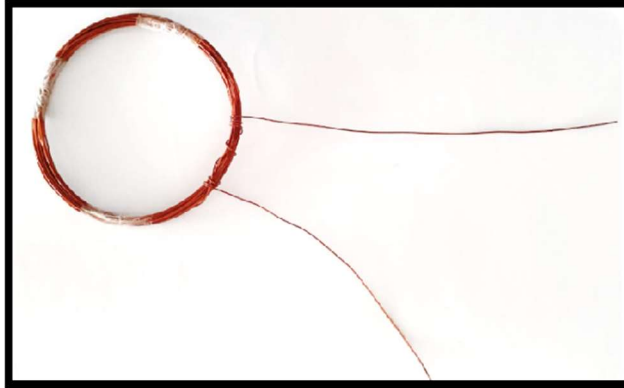

Fig 25. Receiver coil

Rectifier:

The output from the secondary coil is rectified by the use of a rectifier using four diodes connected with each other. The rectifier is used to convert AC to DC. We use a full wave rectifier in this case. The full wave rectifier produces a smooth DC with less ripples. In the positive half of the AC cycle, D1 and D2 conduct because they're forward biased. Positive voltage is on the anode of D1 and negative voltage is on the cathode of D2. Thus, these two diodes work together to pass the first half of the signal through. In the negative half of the AC cycle, D3 and D4 conduct because they're forward biased: Positive voltage is on the anode of D3 and negative voltage is on the cathode of D4. The net effect of the bridge rectifier is that both halves of the AC sine wave are allowed to pass through, but the negative half of the wave is inverted so that it becomes positive to produce pure DC.

LC oscillator circuit:

The electric current and the charge on the capacitor in the circuit undergo electrical LC oscillations when a charged capacitor is connected to an inductor. The LC circuit is used to select or generate a specific frequency signal. The process continues at a definite frequency and if no resistance is present in the LC circuit, then the LC Oscillations will continue indefinitely.

Voltage regulator:

Voltage regulator is used to obtain a constant DC source. We use IC 7805 for this purpose. The number 78 signifies that it is a positive voltage regulator and 05 signifies that it gives 5V output.

A flow chart of the working:-

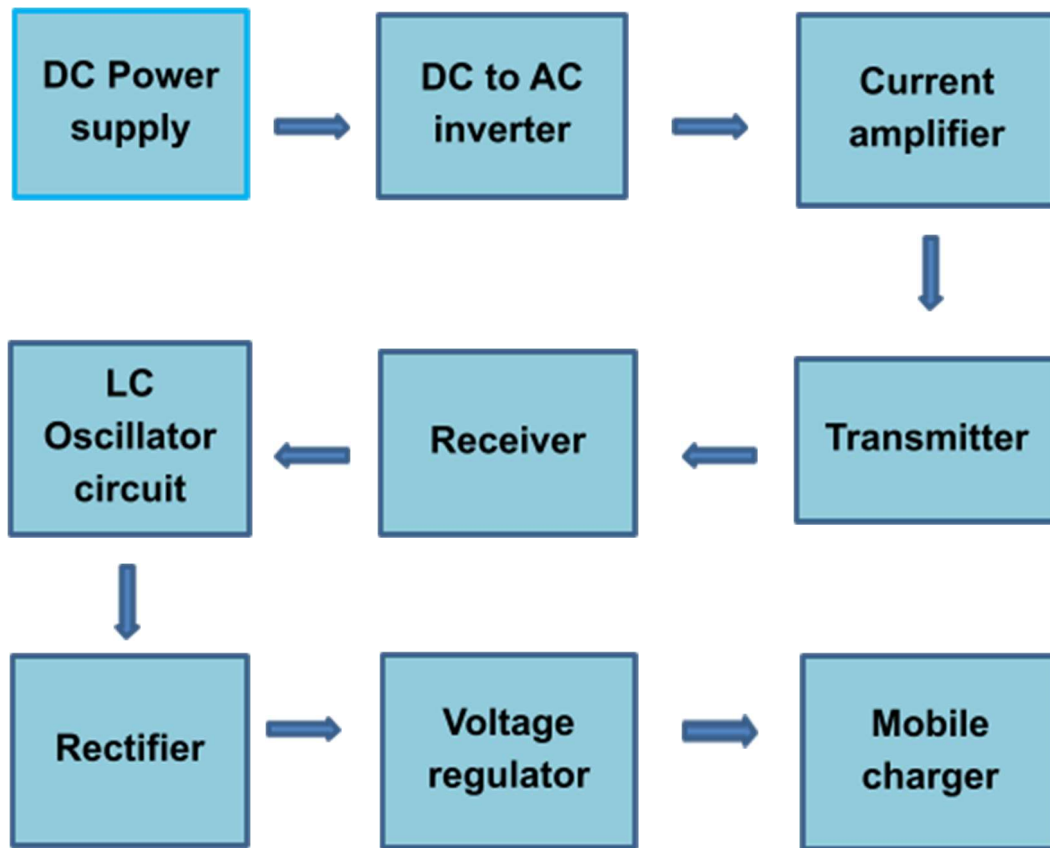

In brief, in our Wireless charging system there are two circuits, a transmitter circuit and a receiver circuit. The transmitter circuit consists of an Z44 MOSFET which converts the DC power supply to AC. Then, with the help of a transmitting coil the wireless power gets transmitted to the receiver circuit. The receiver circuit receives the power through the receiving coil and passes through the rectifier circuit (consisting of diode and capacitor). The AC current received by the receiver coil is converted into DC current with the help of a bridge rectifier. After that a 1000 μF capacitor is used to filter the ripples and pure DC is supplied. The pure DC is then passed through the voltage regulator to get a regulated 5V DC and it is then given to the cable from which the mobile charging is achieved.

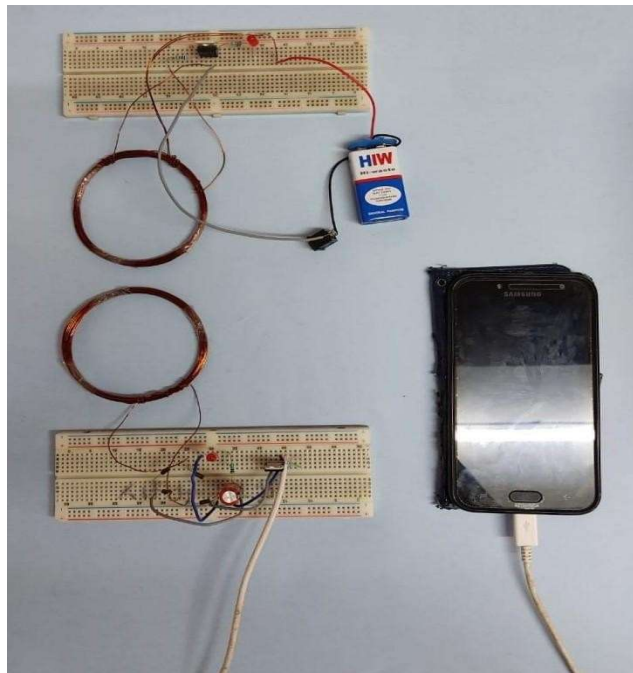

Fig 26. An image of the wireless mobile charger circuit

5.3. DESIGN CALCULATION :

Details of Transmitting Coil:

Radius of the transmitting coil (r) = 3.742 cm
Radius of the cross-section (a) = 0.02483 cm
Number of transmitting coil Turns (N) = 30 turns
Coil wire size = 25 gauge
Diameter= 7.484 cm
Width of the winding= 0.343 cm

Details of Receiving Coil:

Radius of the receiving coil (r) = 3.742 cm
Radius of the cross-section (a) = 0.02483 cm
Number of receiving coil Turns (N) = 30 turns
Coil wire size = 25 gauge
Diameter= 7.484 cm

Width of the winding= 0.343 cm

Theoretical Calculation

Inductance of the Winding:

$$\begin{aligned} \text{Inductance of transmitter coil} &= N^2 \mu_0 r (\ln (8r/a) - 1.75) \dots\dots\dots(3) \\ &= 30^2 \times 4\pi \times 10^{-7} \times 3.742 \left(\ln \ln \left(\frac{(8 \times 3.742)}{0.0248} \right) - 1.75 \right) \\ &= 0.0226 \text{ H} = 22.6 \text{ mH} \end{aligned}$$

$$\begin{aligned} \text{Inductance of receiver coil} &= N^2 \mu_0 r (\ln (8r/a) - 1.75) \\ &= 30^2 \times 4\pi \times 10^{-7} \times 3.742 \left(\ln \ln \left(\frac{(8 \times 3.742)}{0.0248} \right) - 1.75 \right) \\ &= 0.0226 \text{ H} = 22.6 \text{ mH} \end{aligned}$$

Resistance of the winding:

$$\text{Resistance of the Winding (R)} = \rho l/A \dots\dots\dots(4)$$

$$\begin{aligned} \text{Length of transmitter coil (l)} &= \text{Circumference of coil} \times N \\ &= 2\pi \times D \times N \\ &= 2 \times 3.14 \times 7.484 \times 30 \text{ cm} \\ &= 1409.9856 \text{ cm} \end{aligned}$$

$$\begin{aligned} \text{Length of receiver coil (l)} &= \text{Circumference of coil} \times N \\ &= 2\pi \times D \times N \\ &= 2 \times 3.14 \times 7.484 \times 30 \text{ cm} \\ &= 1409.9856 \text{ cm} \end{aligned}$$

$$A = 2\pi r(r+h) \dots\dots\dots(5)$$

where h = width of the winding

$$= 2 \times 3.14 \times 3.742 (3.742 + 0.343) = 95.996 \text{ cm}^2$$

P = Resistivity of Copper = 1.796×10^{-8}

$$\text{Resistance of transmitter coil} = 2.637 \times 10^{-7} \Omega$$

$$\text{Resistance of receiver coil} = 2.637 \times 10^{-7} \Omega$$

Resonant Frequency of the receiver coil:

$$f = \frac{1}{2\pi\sqrt{LC}} = \frac{1}{2 \times 3.14 \times \sqrt{22.6 \times 10^{-3} \times 1000 \times 10^{-6}}} = 33.49 \text{ Hz}$$

$$L = 22.6 \text{ mH}$$

$$C = 1000 \text{ } \mu\text{F (Capacitor Used)}$$

$$f = 33.49 \text{ Hz}$$

Resonance Condition satisfied by the receiver coil:

For Resonance to occur, $X_L = X_C$

X_L = Inductive reactance (Reactance of Coil)

$$= 2\pi \times f \times L = 2 \times 3.14 \times 33.49 \times 22.6 \times 10^{-3} = 4.753 \text{ K}\Omega$$

X_C = Capacitive Reactance

$$= 1/2\pi \times f \times C = 1 \div (2 \times 3.14 \times 33.49 \times 1000 \times 10^{-6}) = 4.753 \text{ K}\Omega$$

Thus, $X_L = X_C$ and so Resonance occurs resulting in transfer of power wirelessly.

5.4. OBSERVATIONS:

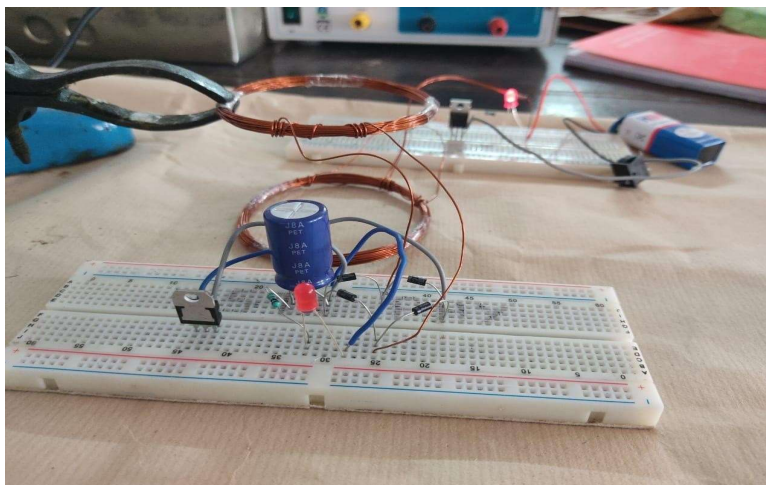

Fig 27. An image of taking observation

1) CASE 1:

No. of turns in primary coil: 20

No. of turns in the secondary coil: 20

Input voltage: 9V

DISTANCE (cm)	OUTPUT VOLTAGE(V)	EFFICIENCY
0	6.2	0.68
0.5	6.06	0.67
1	4.73	0.52
1.5	3.147	0.349
2	2.64	0.293
2.5	2.147	0.238
3	1.81	0.201
3.5	1.71	0.19
4	1.60	0.17
4.5	1.5	0.16
5	1.43	0.15
5.5	1.28	0.14
6	0.87	0.096
6.5	0.78	0.086
7	0.68	0.075

Table 3

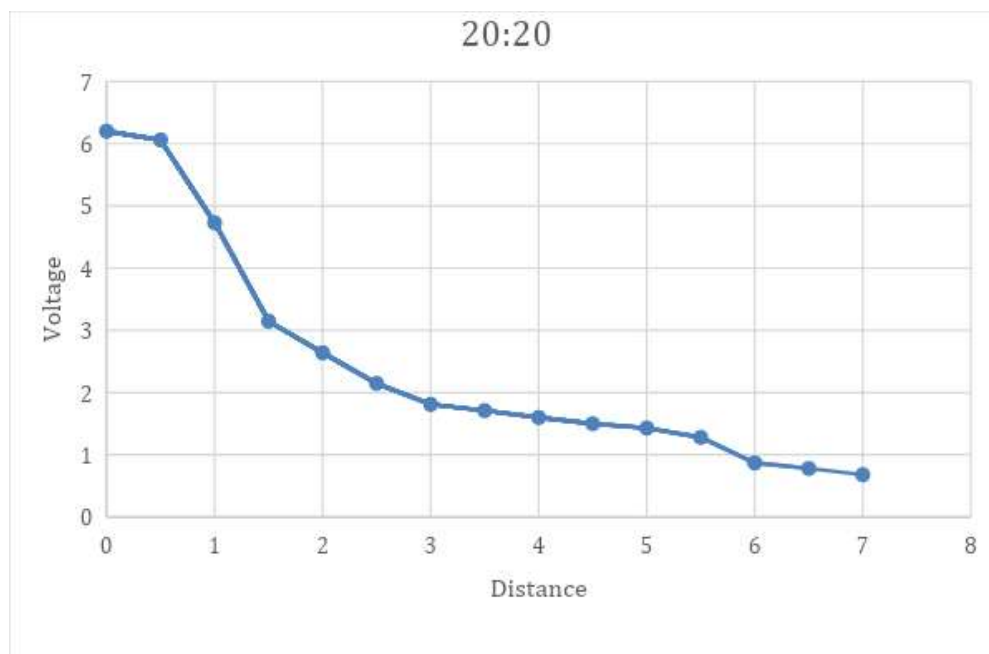

Graph 1. Voltage vs Distance graph (for 20 turns)

2) CASE 2:

No. of turns in primary coil: 30

No. of turns in the secondary coil: 30

Input voltage: 9V

DISTANCE (cm)	OUTPUT VOLTAGE(V)	EFFICIENCY
0	6.92	0.768
0.5	5.52	0.6
1	4.15	0.457
1.5	3.94	0.437
2	3.27	0.363
2.5	2.23	0.247
3	2.09	0.229
3.5	1.9	0.211
4	1.75	0.194
4.5	1.691	0.187
5	1.58	0.175
5.5	1.35	0.15
6	1.15	0.127
6.5	0.861	0.095
7	0.702	0.078
7.5	0.65	0.072
8	0.612	0.068

Table 4

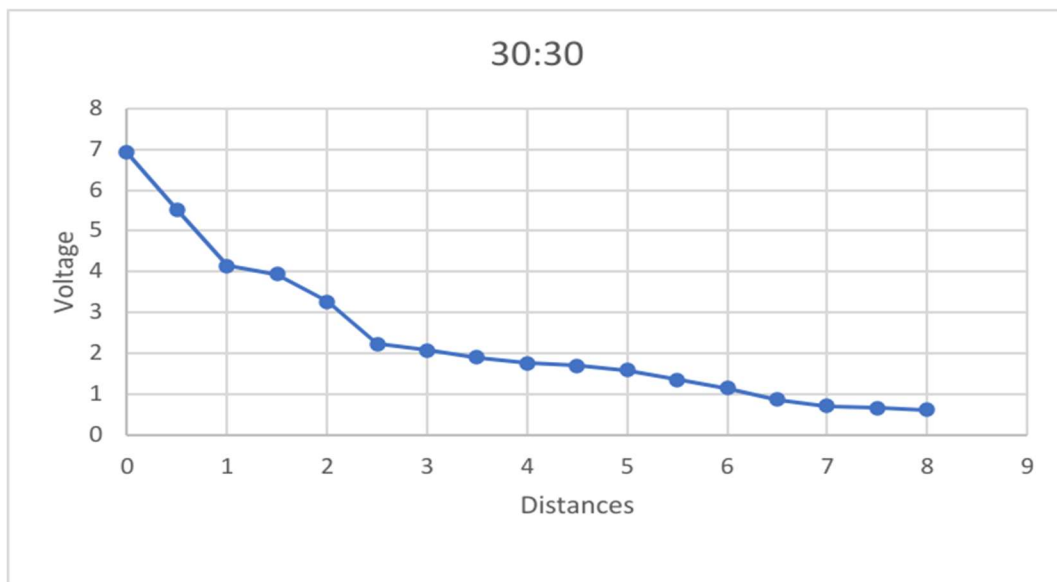

Graph 2. Voltage vs Distance graph (for 30 turns)

CHAPTER - 6

CONCLUSION

Wireless charging is a much convenient and easier system to use for charging various devices. We constructed a wireless mobile charging system using transmitter and receiver coils. The distance between the coils were varied to study the change in output voltage and hence the efficiency. We observed that the efficiency,

(i) decreases with increase in the distance between the coils

(ii) increases with the increase in no of turns.

Thus the predicted theoretical condition matches with the experimental results.

Even though wireless charging is still pretty much in its early stages, the technology is anticipated to evolve dramatically over the next few years.

CHAPTER - 7

MERITS, CHALLENGES AND FUTURE SCOPE OF WIRELESS CHARGING

Wireless charging can be sized to deliver 5W or 10W of energy to the battery. It can also charge a battery at a fast rate depending on the size of the battery pack.

The benefit of having wireless charging is that there won't be any need to deal with cords again. It leaves the need of messy cords and makes it much simpler by just letting you drop your phone at the charging station. With wireless chargers, we are able to charge all your phones simultaneously. One of the best advantages of certain wireless chargers is that it can integrate with almost all cell phones, no matter the shape or size of its charging socket. And also, there are certain devices other than smartphones which can be charged using the wireless charger. When the device is fully charged, the wireless charging pad shuts down automatically. This means that less energy is wasted, safer charging, and there won't be any overheating in the process.

The main disadvantages of inductive charging are its lower efficiency and increased resistive heating in comparison to direct contact. Implementations using lower frequencies or older drive technologies charge more slowly and generate heat for most portable electronics. Inductive Charging also requires drive electronics and coils that increase manufacturing complexity and cost. Newer approaches diminish the transfer losses with ultra-thin coils, higher frequencies and optimized drive electronics, thus providing chargers and receivers that are compact, more efficient and can be integrated into mobile devices or batteries with minimal change. These technologies provide charging time that is the same as wired approaches and are rapidly finding their way into mobile devices.

Wireless charging is a dependable, convenient, and a secure method of powering and charging electrical equipment. It is gaining momentum in healthcare, automotive, aerospace and consumer goods production industries.

Some of them are:

- Solar power satellite
- Wirelessly powered home appliances
- Wirelessly charging of electric vehicles on the way
- Wireless power used in medical devices.
- Wirelessly powered train.

REFERENCES

1. Muhammad Ahsan Javaid, Dr. Kamran Liaqat Bhatti, Engr. Zeeshan Raza, Engr. Umer Ilyas, Shan ul Haq. “Wireless Power Transmission “A Potential Idea for Future”“ International Journal of Scientific & Engineering Research ISSN: 2229-5518, Volume 6, Issue 3, Page: 933-937, March-2015.
2. Murugesan R. “Electricity & Magnetism”, Ninth revised edition, reprint 2013, Publications - S Chand & Company PVT-LTD, Ram Nagar, New Delhi – 110055, Chapter13, Sections 13, 14, 30 and18.
3. Omkar Singh. “Wireless mobile charger” International Journal of Electronics, Electrical and Computational System (IJEECS) ISSN: 2348-117X, Volume 5, Issue 6, Page: 97-105, June 2016.
4. Otchere Peter Kweku. “Wireless mobile charger using inductive coupling” International Journal of Engineering and Advanced Technology (IJEAT) ISSN: 2249 – 8958, Volume-7, Issue-1, Page:84-99, October 2017.
5. Puranam Revanth Kumar “Wireless mobile charger using inductive coupling” Journal of Emerging Technologies and Innovative Research (JETIR) Page: 40-44, October 2018.
6. Sedha R.S, A TextBook of Applied Electronics, revised edition, Publications - S Chand & Company PVT-LTD, Ram Nagar, New Delhi – 110055, Chapter 16, Section 14, 15, 16. 17, 20, 21, 24 and 26.
7. Sumi FH, Dutta L, Sarker F (2018) “Future with Wireless Power Transfer Technology” J Electr Electron Syst 7: 279 ISSN: 2332-0796, Volume 7, Issue 4, Page: 1-7.